

Volts-500 DC Amps-10 to 50A EV Fuses For New Energy Vehicles

10CT5 Series

The Prosemi EV (Electric Vehicle) fuses are made of high strength ceramic tube and high purity melt, with unique arc extinction filling technology which is Prosemi's patent technology. The EV fuses are elaborately designed according to the actual driving status of EVs, with adherence to auto industry standards (JASO, D622/ISO8820). With high vibration durability, perfect transient current intermittent tolerance, eminent thermal shock resistance and favorable flame retardant ability, the Prosemi fuses will provide you protection whether the vehicle is traveling on a flat road or under a variety of harsh conditions.



Features

- DC fuse for EV/HEV/ESS
- Stud-mount, optional for other installation
- Excellent DC performance
- Design to EV fuse standard UL248-20
- Reliability performance design refer to ISO8820-8&GB/T31465.6
- Comply RoHS directive



Specification

Part Number	Rated Current (A)	Rated Voltage/ Interrupting rating	I^2t (A ² s) Melting Pre-arc	Typical Cold Resistance (moh m)	Typical Voltage Drop (mV)
10CT5-10A	10	500Vdc/20000A	130	13.5	185
10CT5-20A	20		435	5.1	145
10CT5-30A	30		1650	3.1	150
10CT5-40A	40		2850	2.2	150
10CT5-50A	50		5250	1.65	165

- Temperature Rise : <=50K with 70% of rated current
- Typical pre-arcing I^2t measured at 10In

Part Numbering System

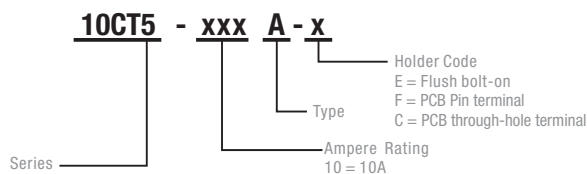

Volts-500VDC Amps-10 to 50A
Fuses For New Energy Vehicles

10CT5 Series

Dimension

Unit: mm

10CT5-xxA-E

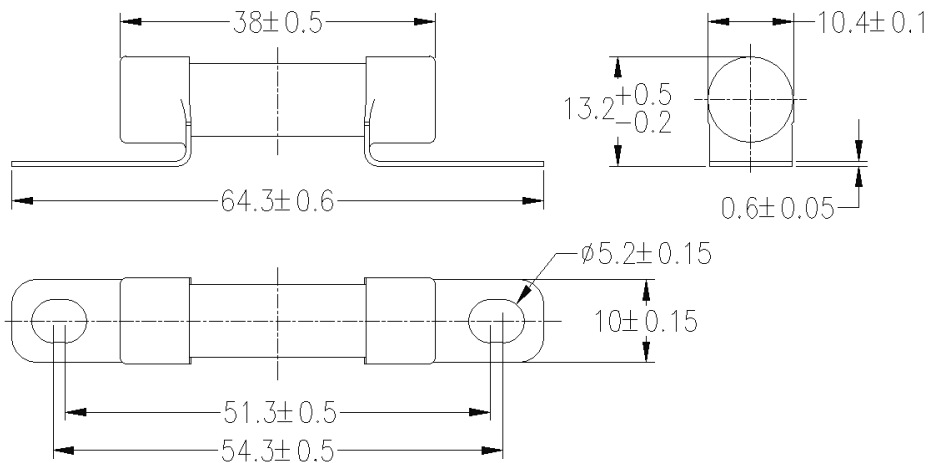

Note: recommend tightening torque is 3.5-4.0Nm.

10CT5-xxA-F

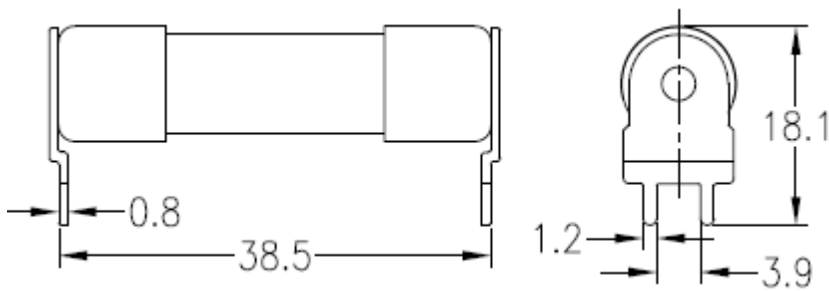

10CT5-xxA-P

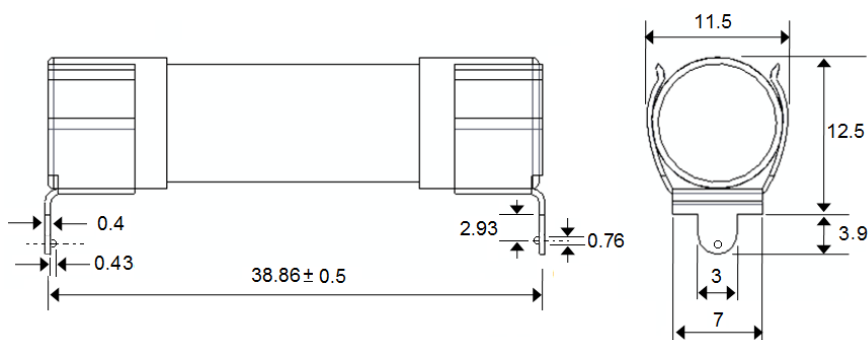

Volts-500 VDC Amps-10 to 50A

Fuses For New Energy Vehicles

10CT5 Series

Average Time Current Curves

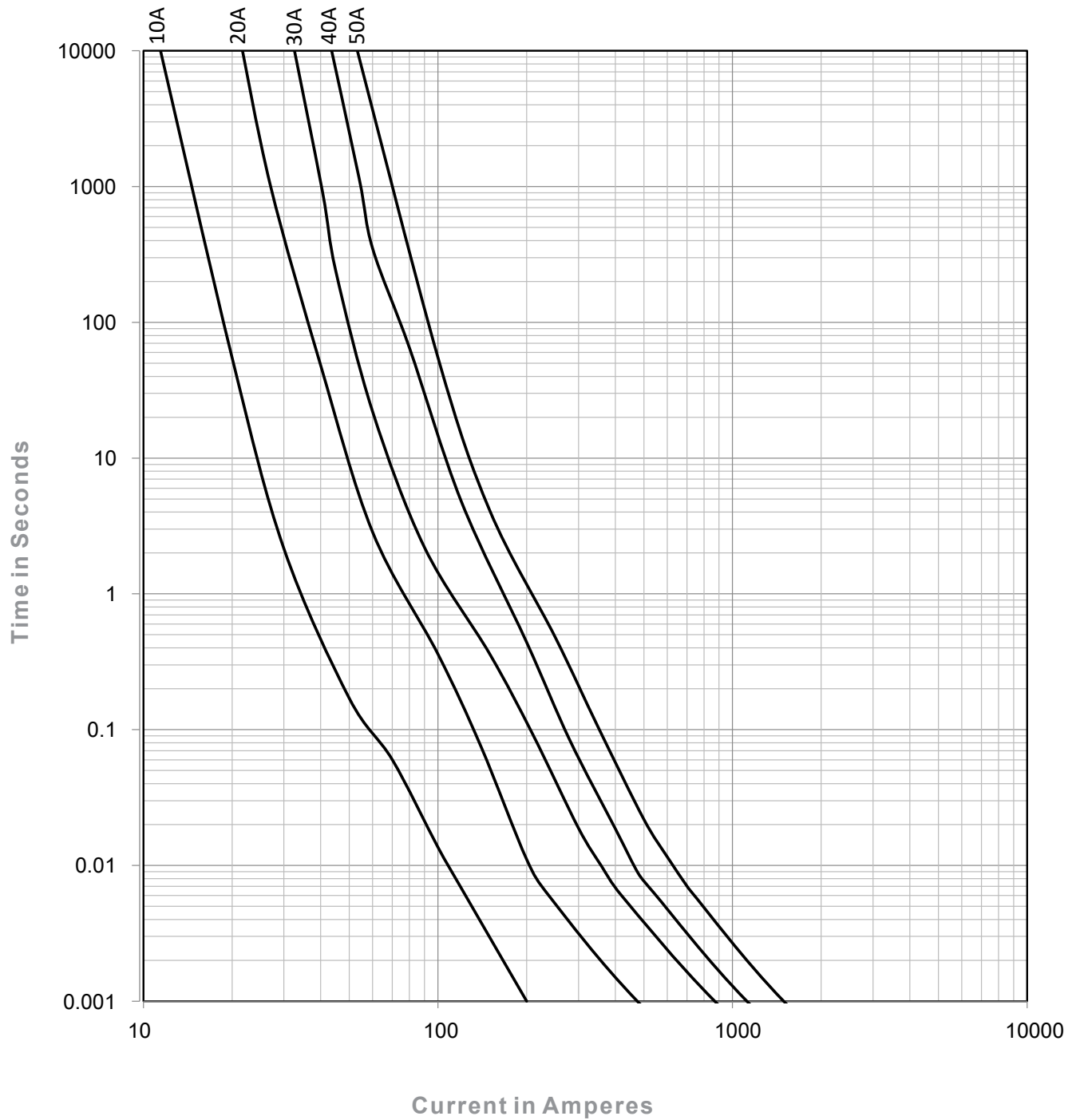

Volts-500 VDC Amps-10 to 50A

Fuses For New Energy Vehicles

10CT5 Series

Soldering Parameter:

- Wave soldering:
Solder Pot Temperature: 270°C Max. Solder Dwell Time: 10s Max.
- Hand-Soldering (not recommended): Solder Iron Temperature: 350°C+/- 5°C Heating Time: 5s Max.

Transportation and Storage

During transportation and storage, should avoid water seepage and mechanical damage.

Conditions for operation in service

Where the following conditions apply, fuses complying with this standard are deemed capable of operating satisfactorily without further qualification.

If the operating conditions exceed the following requirements, please contact manufacturer.

- Normal temperature: -5°C to 40°C;
- The altitude of the site of installation of the fuses does not exceed 2 000 m above sea level;
- The air is clean and its relative humidity does not exceed 50% at the maximum temperature of 40°C;
- Higher relative humidities are permitted at lower temperatures, e.g. 90 % at 20°C;
- Under these conditions, moderate condensation may occasionally occur due to variation in temperature.

Vibration

Meet JASO D622:2006 Section 6.3.3 Vibration durability test requirement, can be use on Electrical Vehicle application;

Temperature Derating Curve

Operating Temperature: -40°C to +125°C, with proper rerating factor applied.

